

8 7 6 5 4 3 2 1

F

F

E

E

D

D

C

C

B

B

A

A

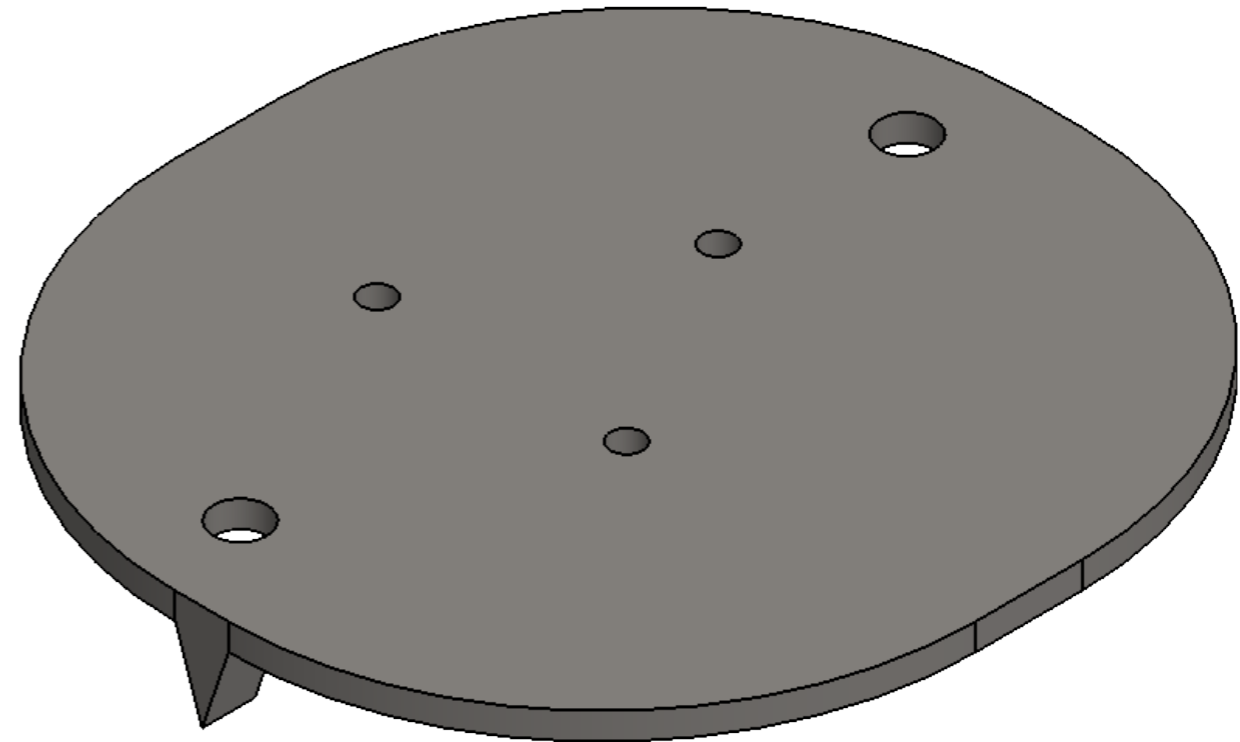
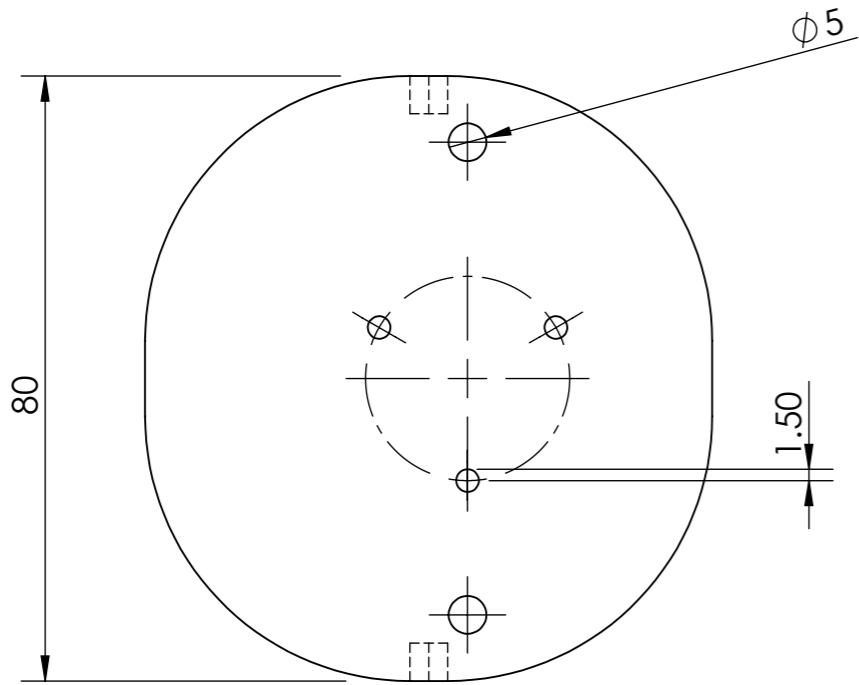
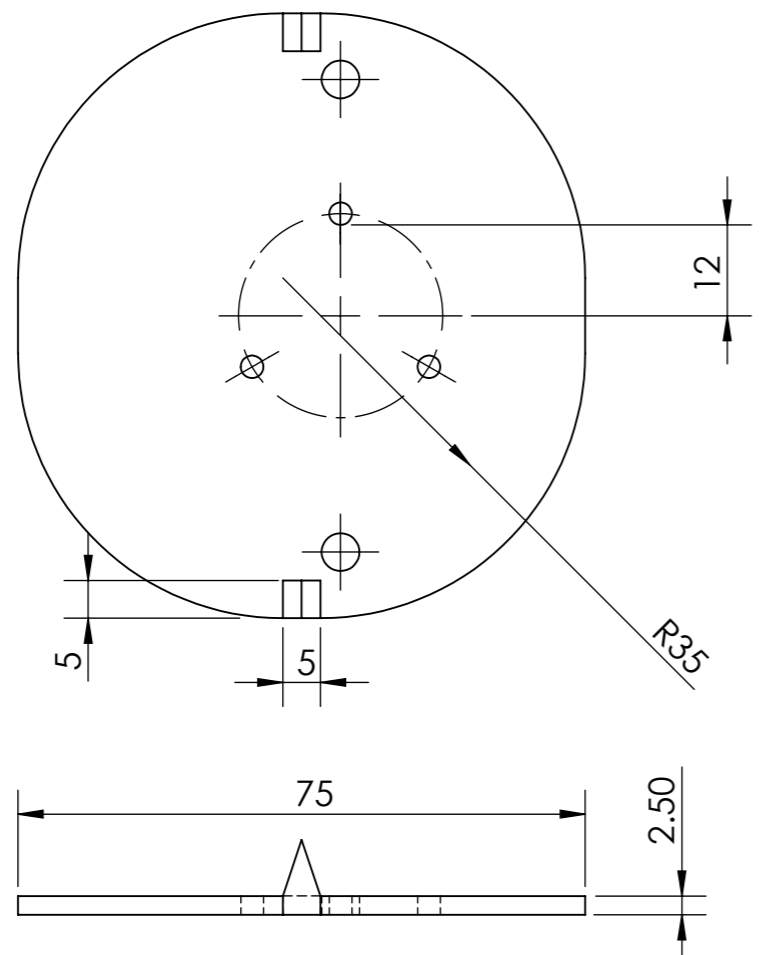

UNLESS OTHERWISE SPECIFIED: DIMENSIONS ARE IN MILLIMETERS				FINISH:		DEBURR AND BREAK SHARP EDGES		DO NOT SCALE DRAWING		REVISION	
SURFACE FINISH: TOLERANCES: +/- 0.1mm											
LINEAR:											
ANGULAR:											
DRAWN		NAME		SIGNATURE		DATE		TITLE:		Wedge	
CHK'D											
APPV'D											
MFG											
Q.A								MATERIAL:		Stainless Steel	
								DWG NO.:		TPDSIMS Part 1	
								WEIGHT:		A3	
								SCALE:1:1		SHEET 1 OF 1	

8 7 6 5 4 3 2 1

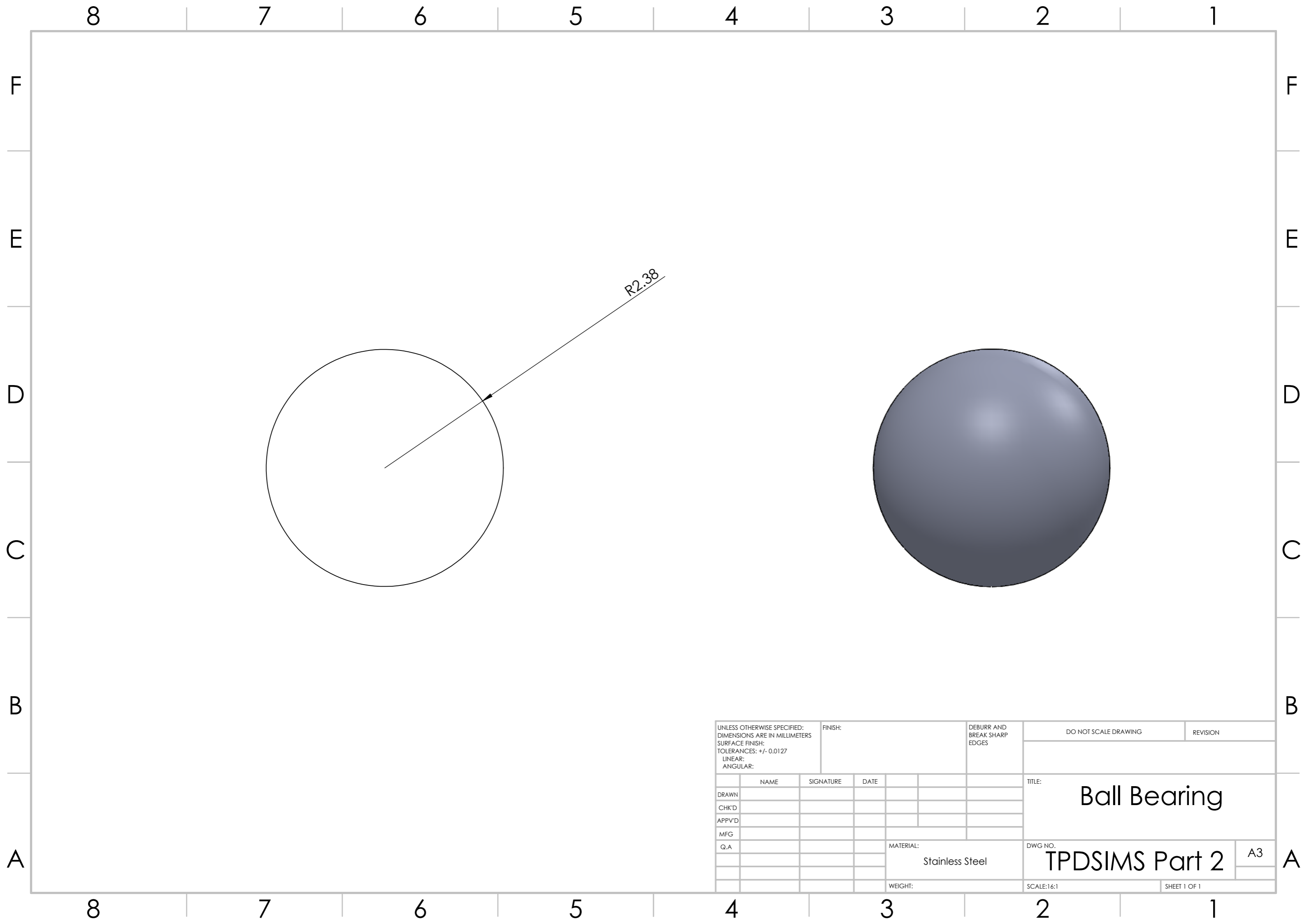

R2.38

UNLESS OTHERWISE SPECIFIED:  
 DIMENSIONS ARE IN MILLIMETERS  
 SURFACE FINISH:  
 TOLERANCES: +/- 0.0127  
 LINEAR:  
 ANGULAR:

FINISH:

DEBURR AND  
 BREAK SHARP  
 EDGES

DO NOT SCALE DRAWING

REVISION

	NAME	SIGNATURE	DATE
DRAWN			
CHK'D			
APPV'D			
MFG			
Q.A			

TITLE:  
**Ball Bearing**

MATERIAL:  
 Stainless Steel

DWG NO.  
**TPDSIMS Part 2**

A3

WEIGHT:

SCALE:16:1

SHEET 1 OF 1

8 7 6 5 4 3 2 1

F

F

E

E

D

D

C

C

B

B

A

A

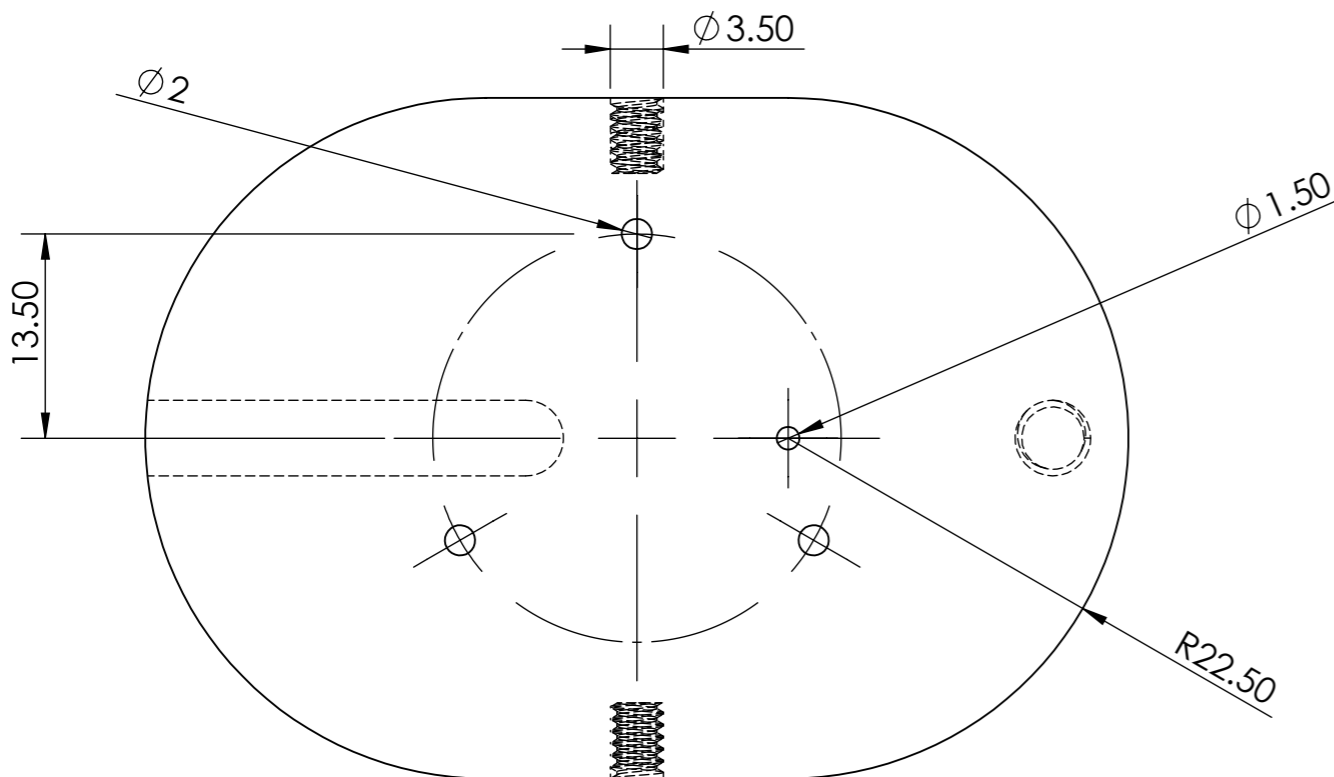
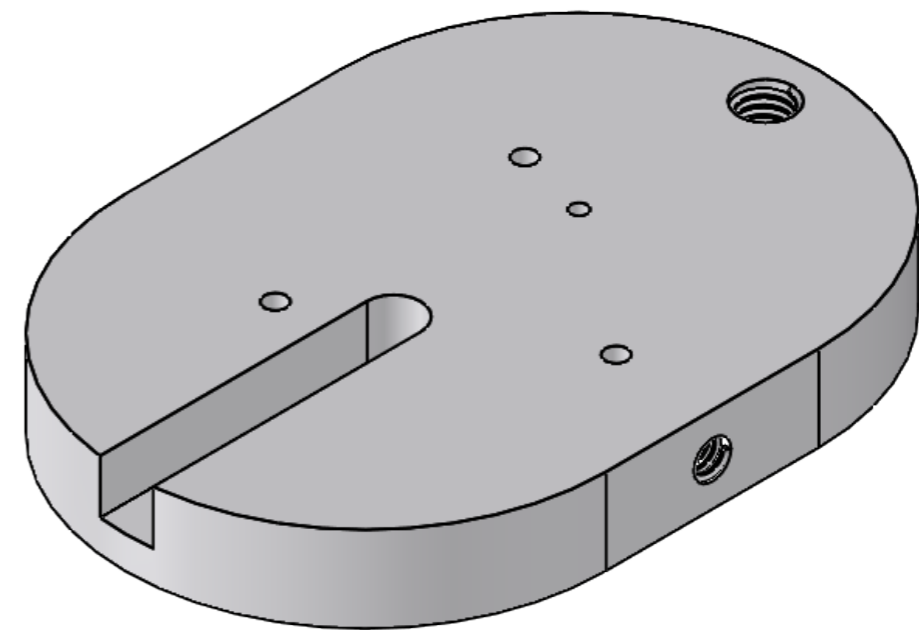
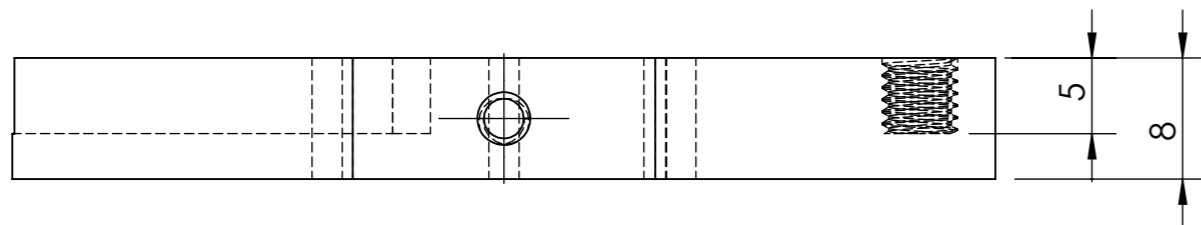
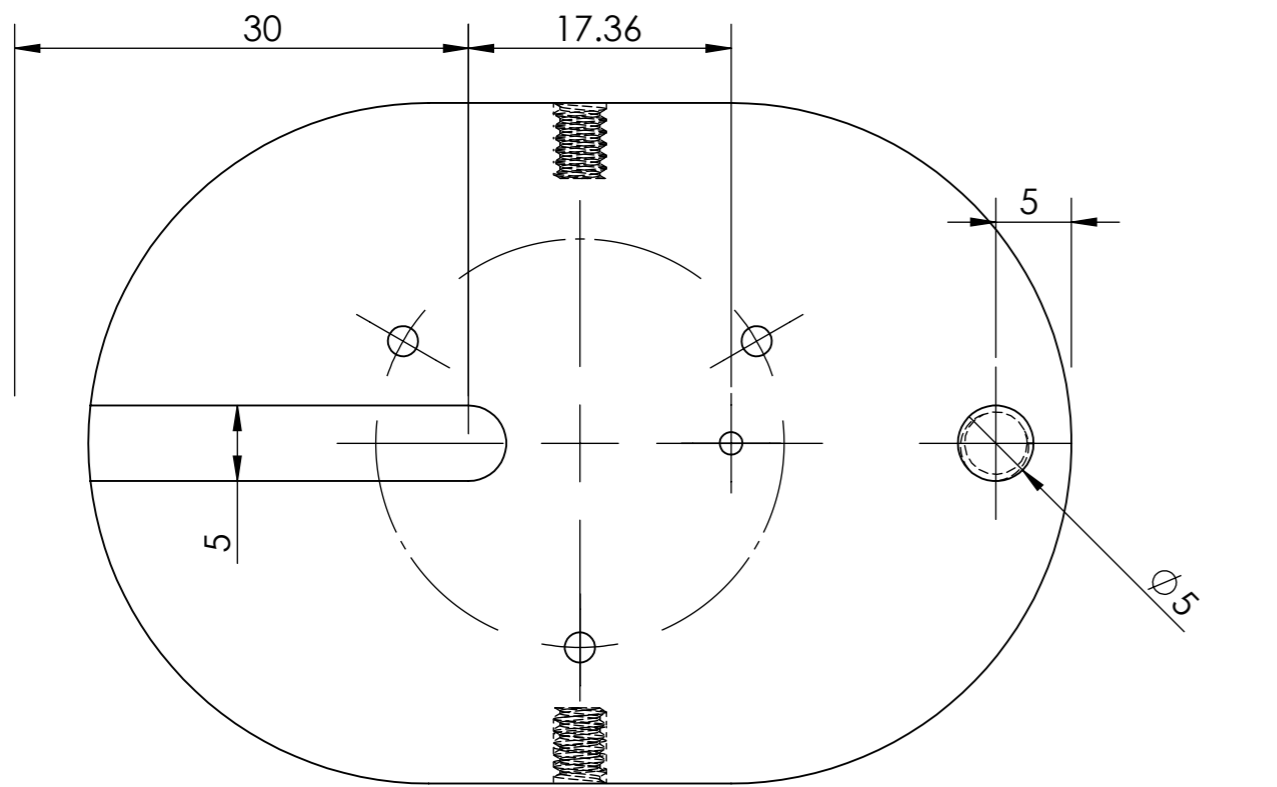

UNLESS OTHERWISE SPECIFIED: DIMENSIONS ARE IN MILLIMETERS				FINISH:		DEBURR AND BREAK SHARP EDGES		DO NOT SCALE DRAWING		REVISION	
SURFACE FINISH: TOLERANCES: +/- 0.02mm								TITLE: <b>Insulator Base</b>			
LINEAR:											
ANGULAR:								DWG NO. <b>TPDSIMS Part 3</b>			
DRAWN				NAME		SIGNATURE					
CHK'D											
APPV'D											
MFG											
Q.A								MATERIAL: Ceramic		SCALE:2:1	
								WEIGHT:		SHEET 1 OF 1	

8 7 6 5 4 3 2 1

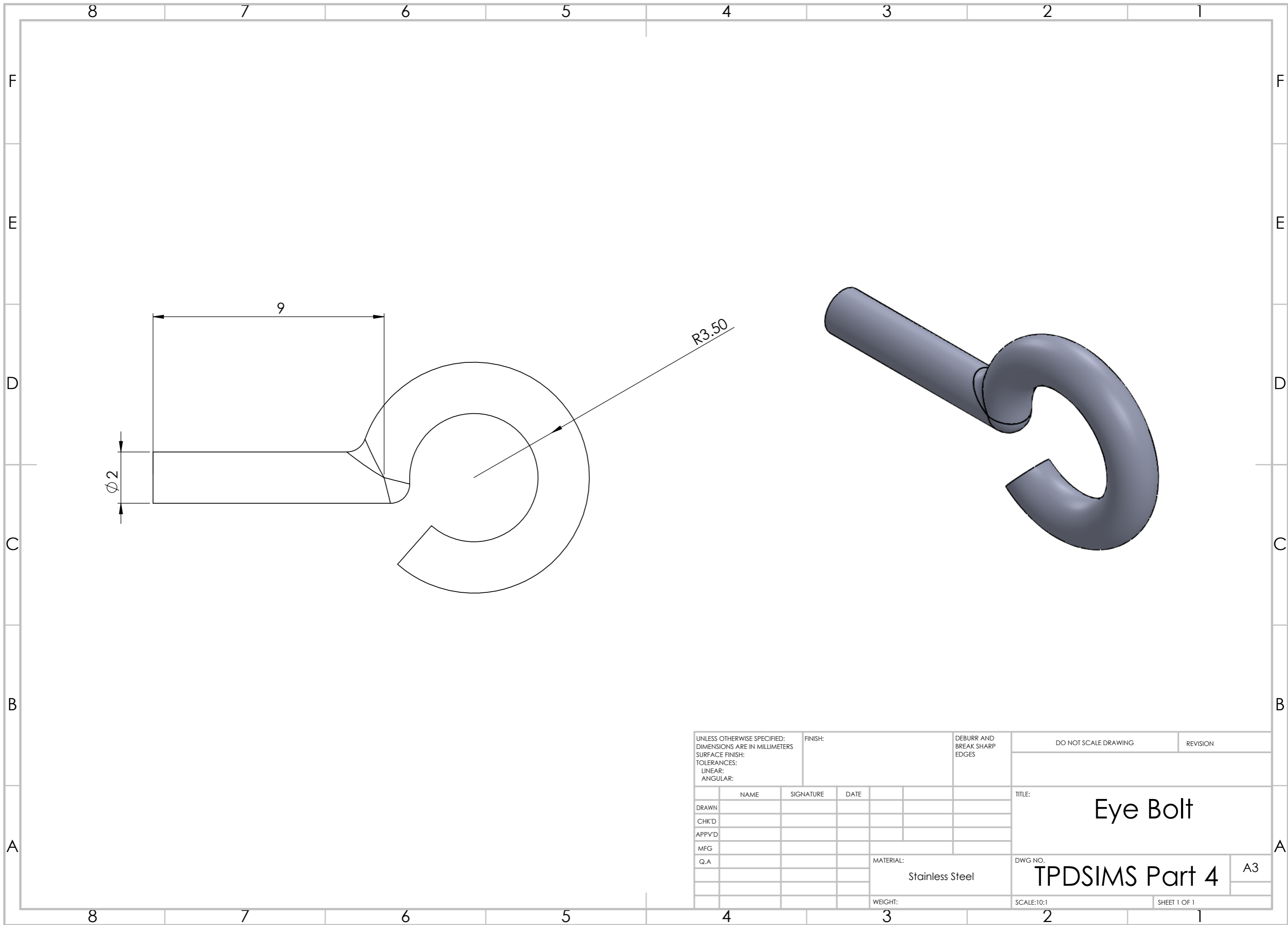

UNLESS OTHERWISE SPECIFIED: DIMENSIONS ARE IN MILLIMETERS SURFACE FINISH: TOLERANCES: LINEAR: ANGULAR:				FINISH:		DEBURR AND BREAK SHARP EDGES		DO NOT SCALE DRAWING		REVISION	
								TITLE: <h1>Eye Bolt</h1>			
DRAWN						MATERIAL:		DWG NO.		A3	
CHK'D						Stainless Steel		TPDSIMS Part 4			
APPV'D								SCALE:10:1		SHEET 1 OF 1	
MFG											
Q.A											
						WEIGHT:					

8 7 6 5 4 3 2 1

F

F

E

E

D

D

C

C

B

B

A

A

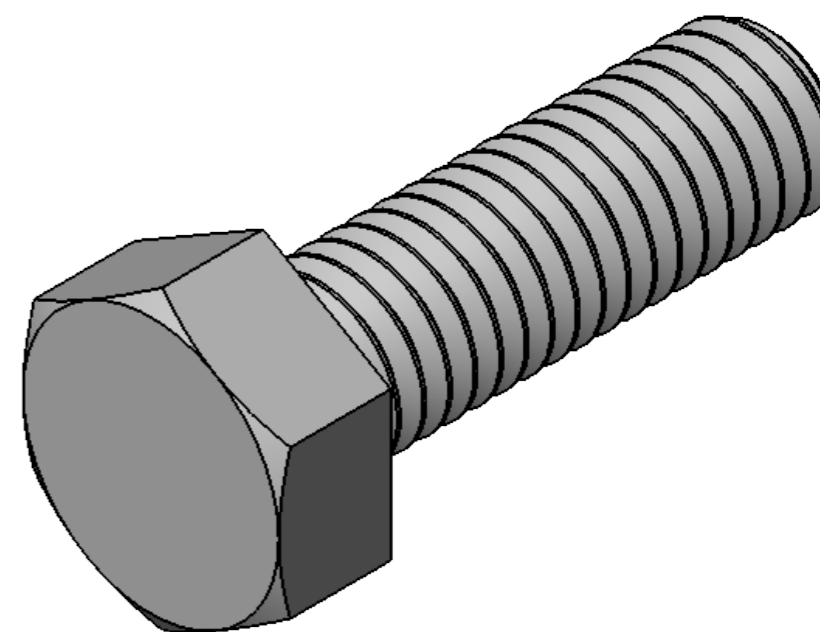
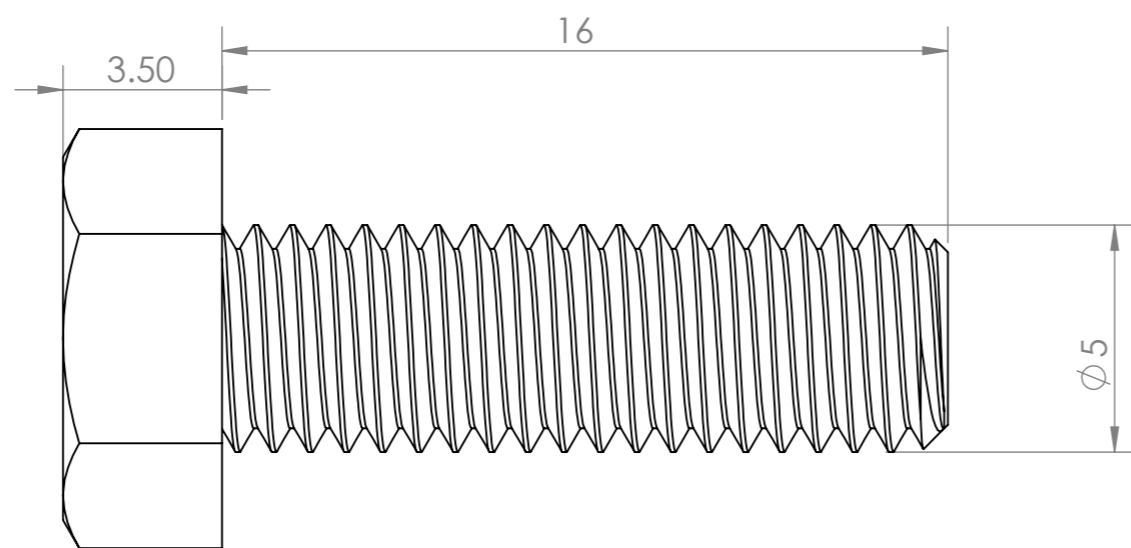
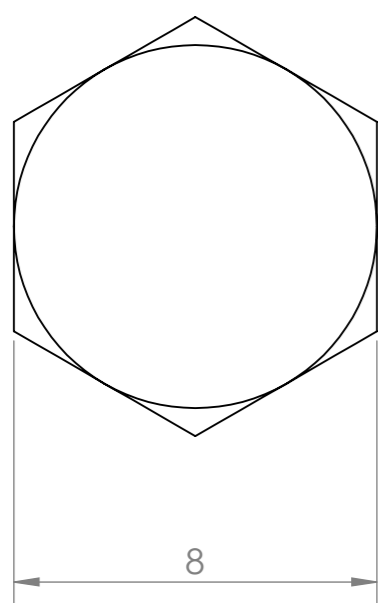

UNLESS OTHERWISE SPECIFIED: DIMENSIONS ARE IN MILLIMETERS SURFACE FINISH: TOLERANCES: LINEAR: ANGULAR:			FINISH:		DEBURR AND BREAK SHARP EDGES		DO NOT SCALE DRAWING		REVISION		
DRAWN			NAME		SIGNATURE		DATE		TITLE: <b>Hex Bolt 16mm</b>		
CHK'D											
APPV'D											
MFG											
Q.A							MATERIAL: Stainless Steel		DWG NO. <b>TPDSIMS Part 5</b>		A3
							WEIGHT:		SCALE:4:1		SHEET 1 OF 1

8 7 6 5 4 3 2 1

8

7

6

5

4

3

2

1

F

F

E

E

D

D

C

C

B

B

A

A

8

7

6

5

4

3

2

1

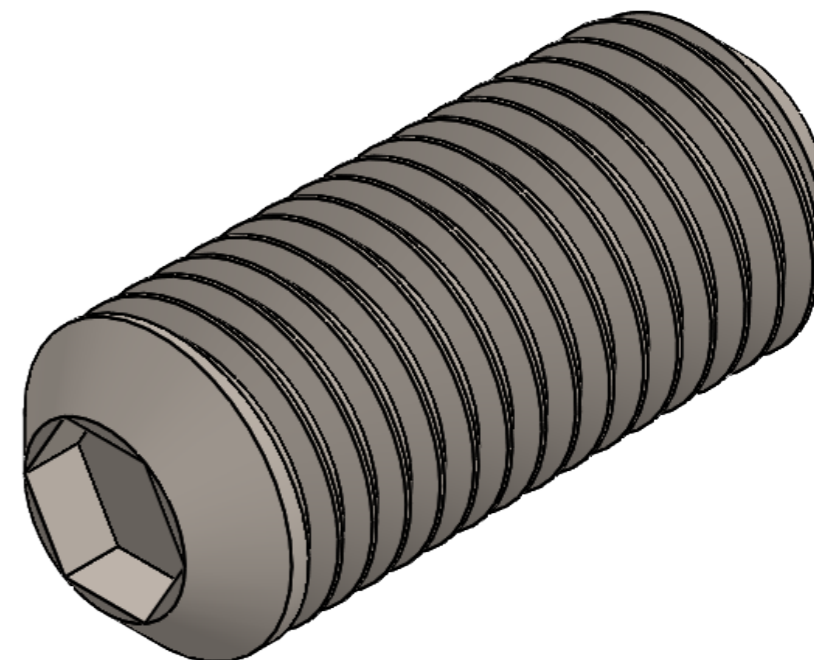
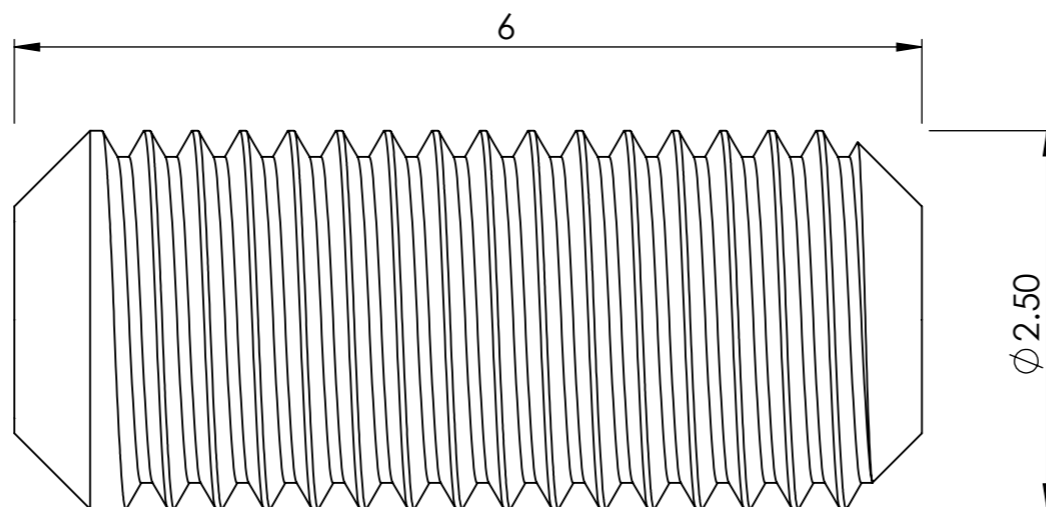
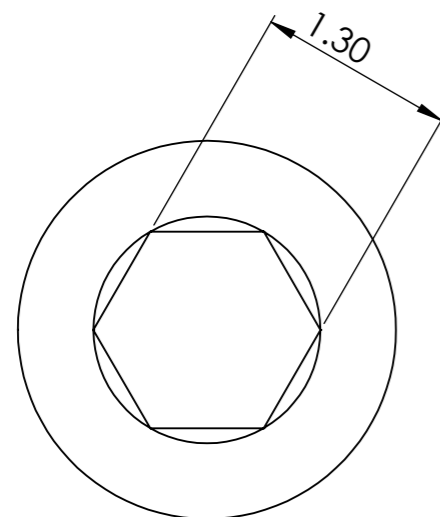

UNLESS OTHERWISE SPECIFIED: DIMENSIONS ARE IN MILLIMETERS SURFACE FINISH: TOLERANCES: LINEAR: ANGULAR:				FINISH:		DEBURR AND BREAK SHARP EDGES		DO NOT SCALE DRAWING		REVISION	
DRAWN				NAME		SIGNATURE		DATE		TITLE: <b>Set Screw</b>	
CHK'D											
APPV'D											
MFG											
Q.A								MATERIAL: Stainless Steel		DWG NO. <b>TPDSIMS Part 6</b>	
								WEIGHT:		SCALE:10:1	
										SHEET 1 OF 1	
										A3	

8 7 6 5 4 3 2 1

F

F

E

E

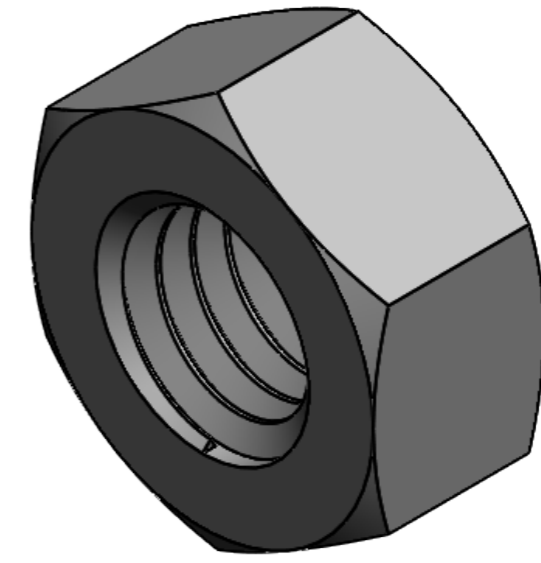
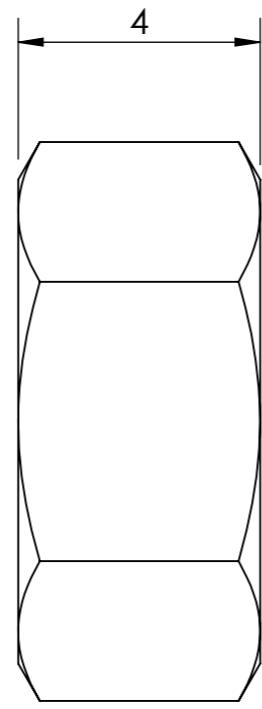
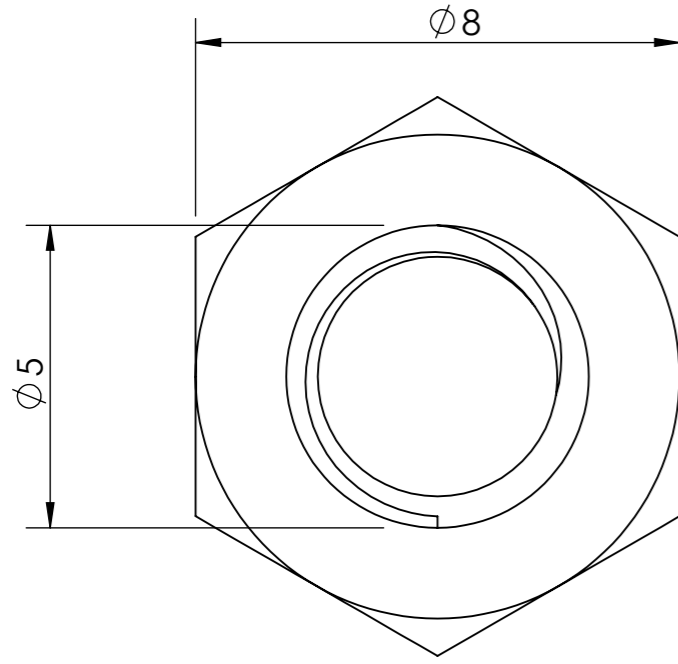

D

D

C

C

B

B

A

A

8 7 6 5 4 3 2 1

UNLESS OTHERWISE SPECIFIED: DIMENSIONS ARE IN MILLIMETERS			FINISH:		DEBURR AND BREAK SHARP EDGES		DO NOT SCALE DRAWING		REVISION	
SURFACE FINISH:										
TOLERANCES:										
LINEAR:										
ANGULAR:										
	NAME	SIGNATURE	DATE				TITLE: <b>Hex Nut</b>			
DRAWN										
CHK'D										
APPV'D										
MFG										
Q.A						MATERIAL: Stainless Steel	DWG NO. TPDSIMS Part 7		A3	
						WEIGHT:	SCALE:8:1		SHEET 1 OF 1	

8 7 6 5 4 3 2 1

F

F

E

E

D

D

C

C

B

B

A

A

8

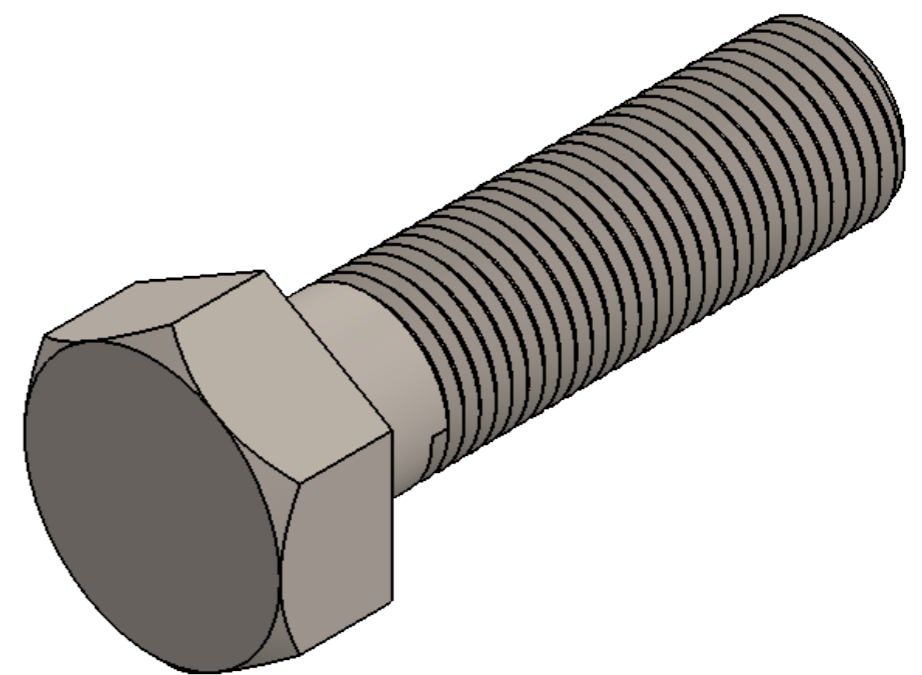
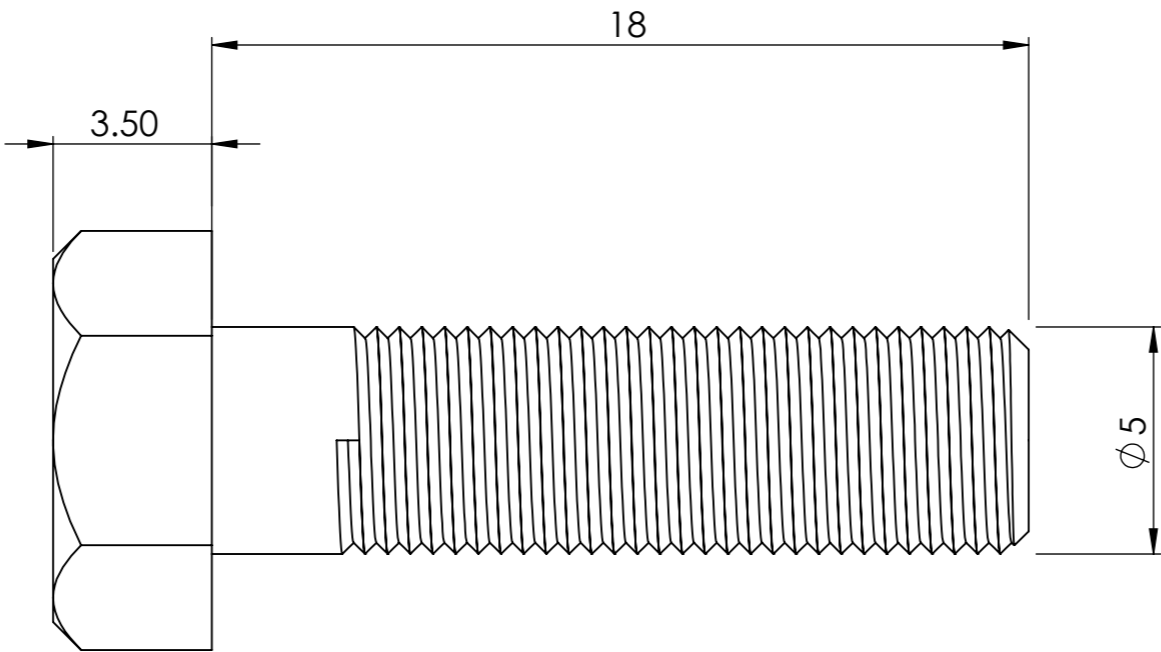
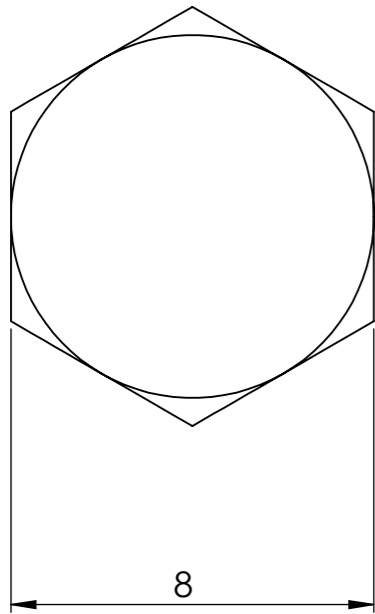

UNLESS OTHERWISE SPECIFIED: DIMENSIONS ARE IN MILLIMETERS SURFACE FINISH: TOLERANCES: LINEAR: ANGULAR:			FINISH:		DEBURR AND BREAK SHARP EDGES		DO NOT SCALE DRAWING		REVISION		
DRAWN			NAME		SIGNATURE		DATE		TITLE: <b>Hex Bolt 18mm</b>		
CHK'D											
APPV'D											
MFG											
Q.A									MATERIAL: Stainless Steel		DWG NO. <b>TPDSIMS Part 8</b>
									WEIGHT:		SCALE:5:1
											SHEET 1 OF 1
											A3

8 7 6 5 4 3 2 1



8 7 6 5 4 3 2 1

F

F

E

E

D

D

C

C

B

B

A

A

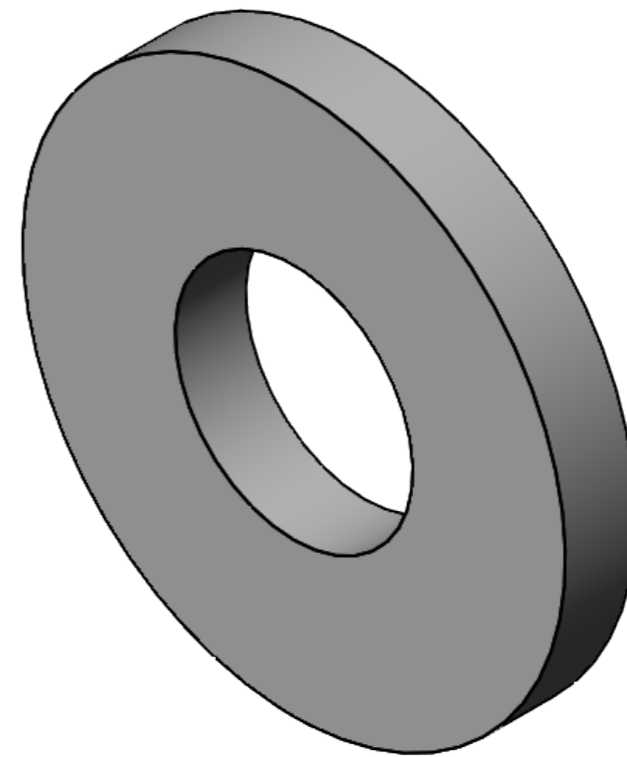
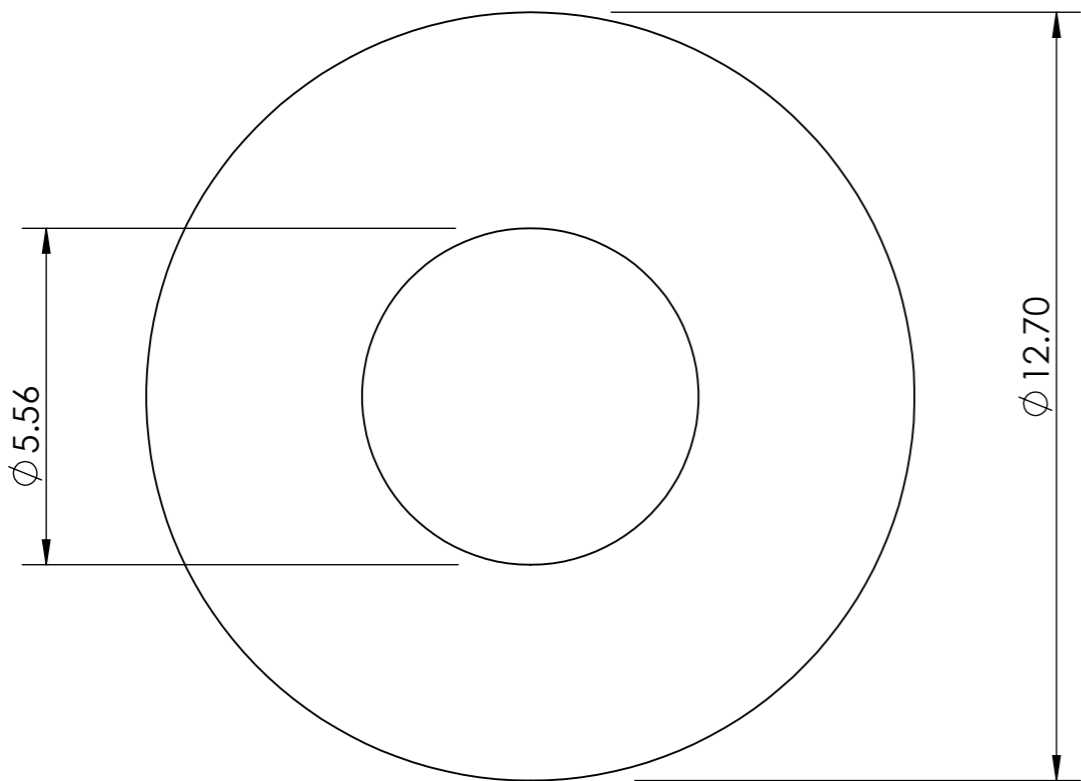
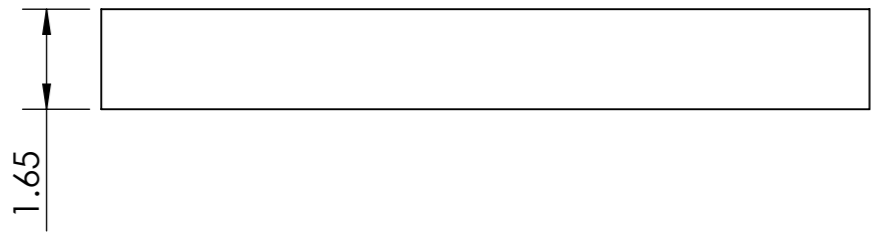

UNLESS OTHERWISE SPECIFIED: DIMENSIONS ARE IN MILLIMETERS SURFACE FINISH: TOLERANCES: LINEAR: ANGULAR:				FINISH:		DEBURR AND BREAK SHARP EDGES		DO NOT SCALE DRAWING		REVISION	
								TITLE: <b>Washer</b>			
								DWG NO. <b>TPDSIMS Part 9</b>		A3	
								MATERIAL: Stainless Steel		SCALE:8:1	
								WEIGHT:		SHEET 1 OF 1	
DRAWN	NAME	SIGNATURE	DATE								
CHK'D											
APPV'D											
MFG											
Q.A											

8 7 6 5 4 3 2 1

8 7 6 5 4 3 2 1

F

F

E

E

D

D

C

C

B

B

A

A

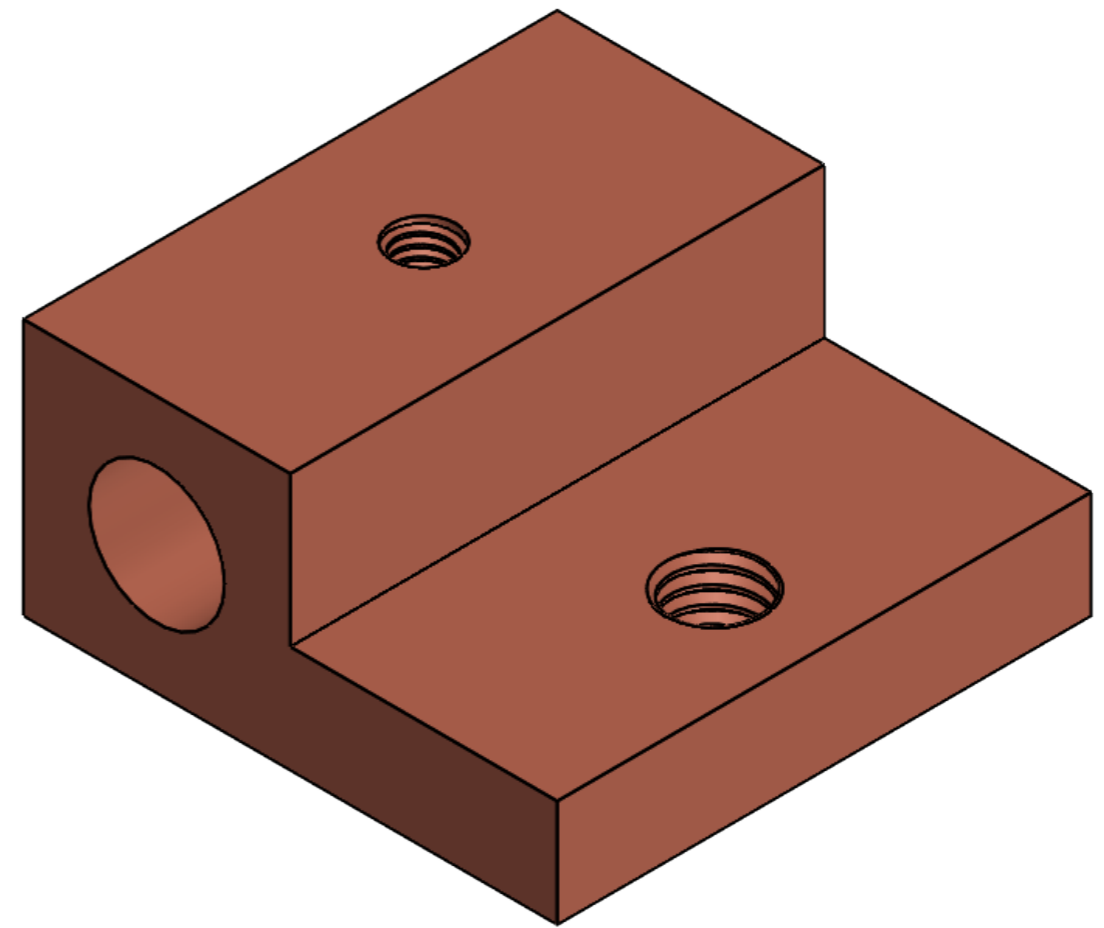
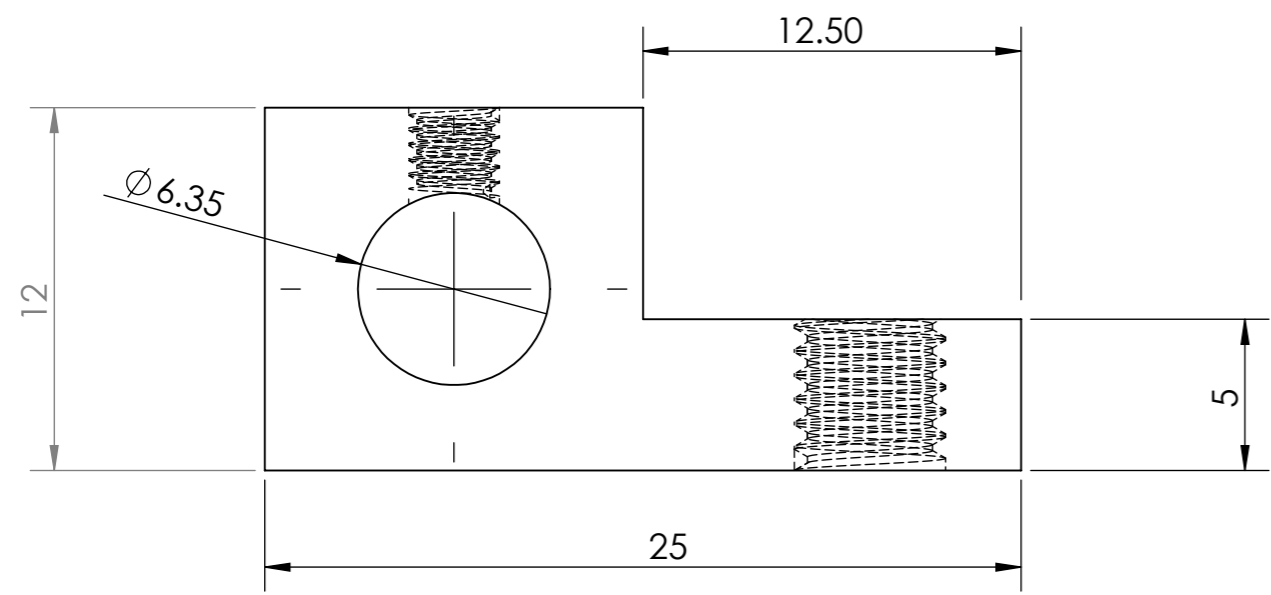
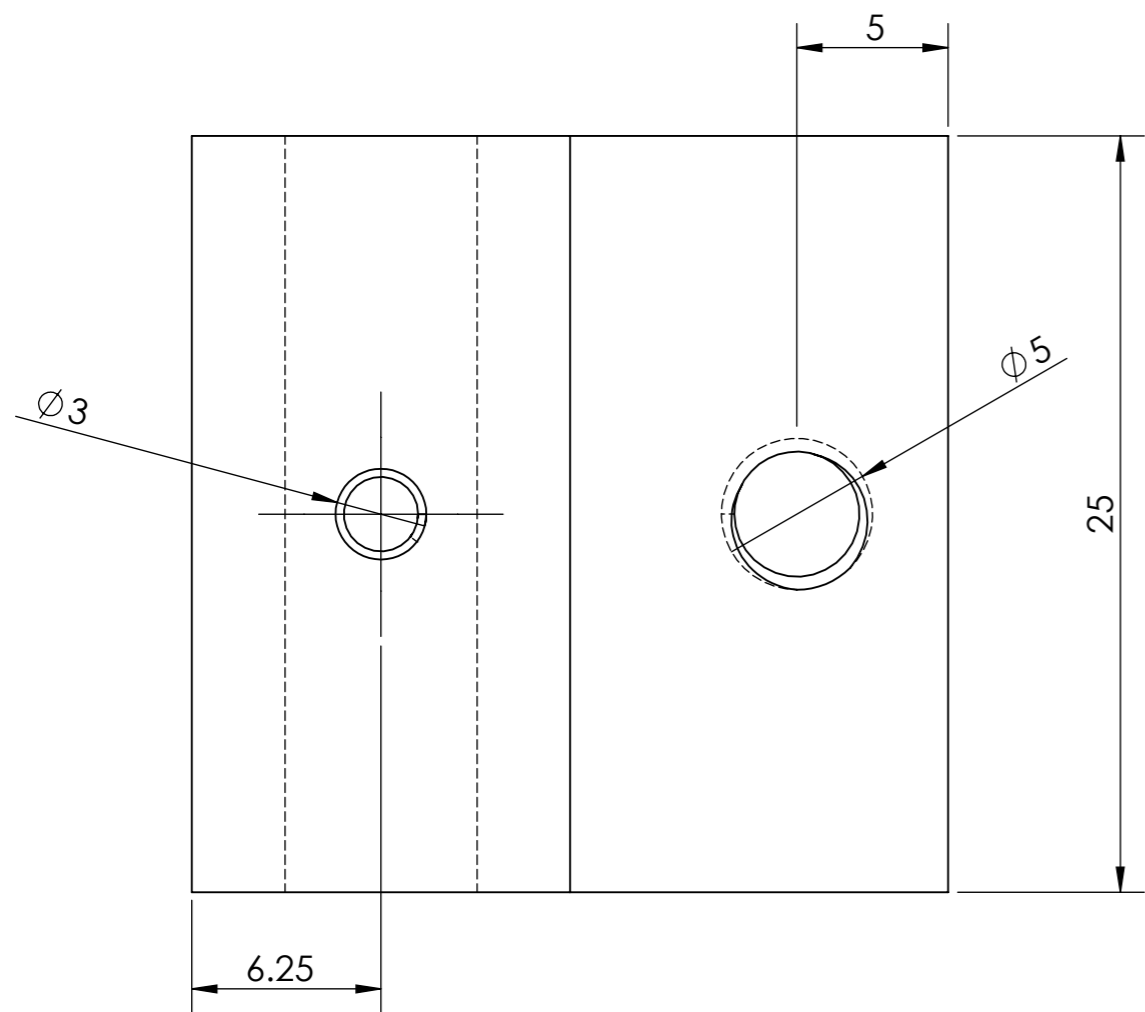

UNLESS OTHERWISE SPECIFIED: DIMENSIONS ARE IN MILLIMETERS			FINISH:		DEBURR AND BREAK SHARP EDGES		DO NOT SCALE DRAWING		REVISION		
SURFACE FINISH:											
TOLERANCES: +/- 0.1mm											
LINEAR:											
ANGULAR:											
DRAWN		NAME		SIGNATURE		DATE		TITLE:		Copper Clamp	
CHK'D											
APPV'D											
MFG											
Q.A								MATERIAL:		Copper	
								DWG NO.:		TPDSIMS Part 10	
								SCALE:4:1		A3	
								WEIGHT:		SHEET 1 OF 1	

8 7 6 5 4 3 2 1

8 7 6 5 4 3 2 1

F

F

E

E

D

D

C

C

B

B

A

A

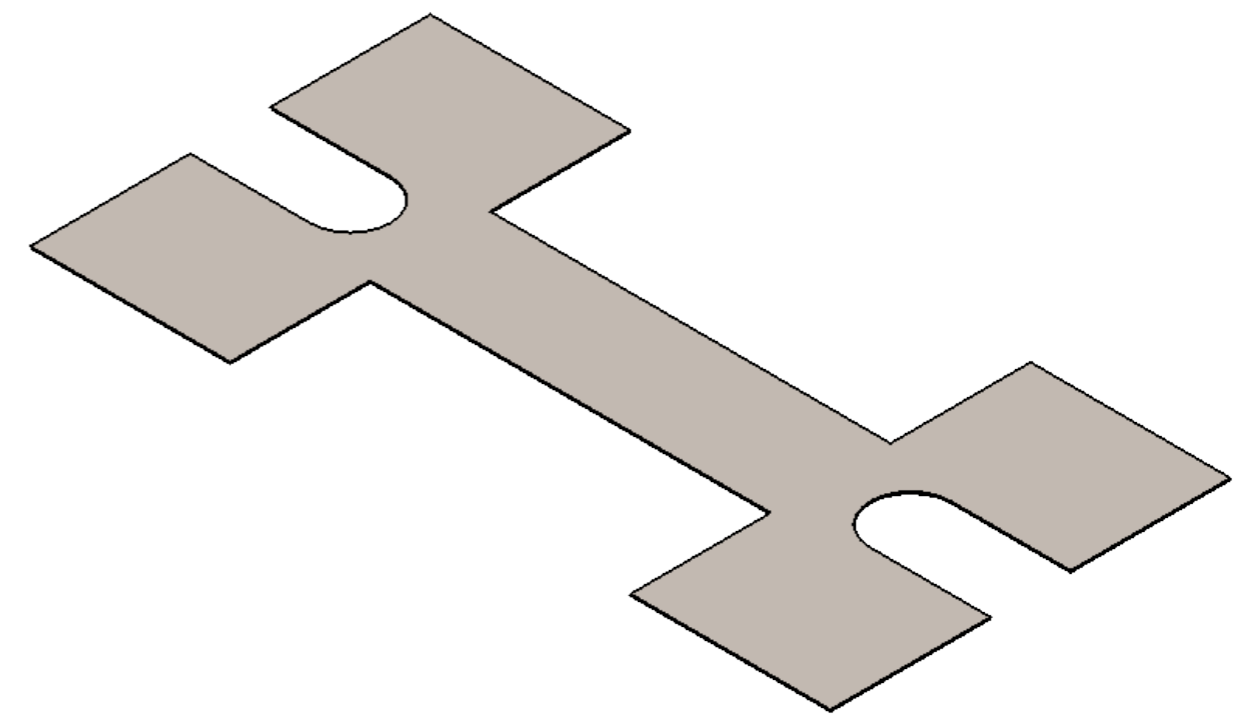
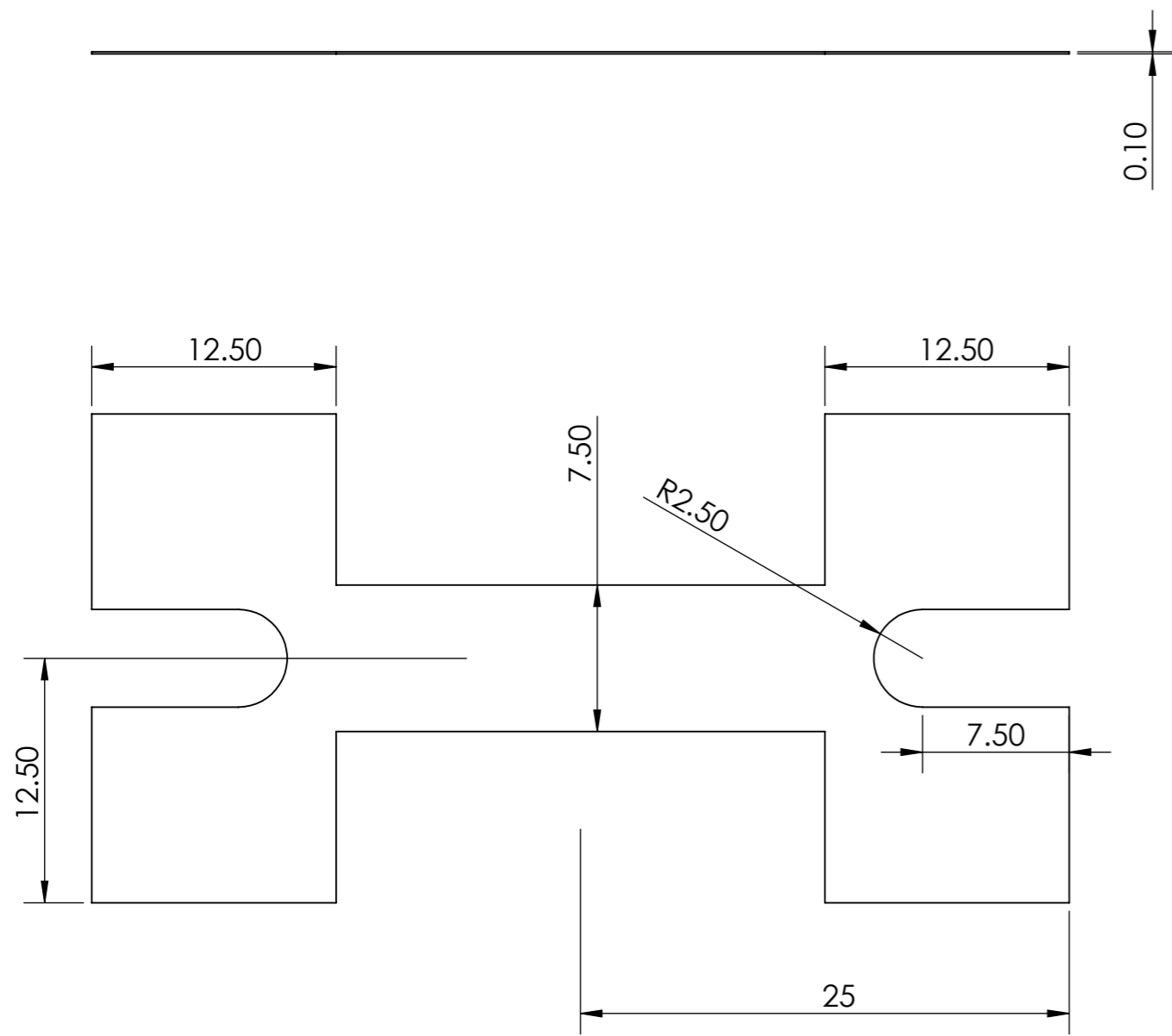

UNLESS OTHERWISE SPECIFIED: DIMENSIONS ARE IN MILLIMETERS		FINISH: Needs to be manufactured in a clean environment with clean tool in order to be oxide free. Also, must be polished:		DEBURR AND BREAK SHARP EDGES		DO NOT SCALE DRAWING		REVISION	
SURFACE FINISH:									
TOLERANCES:									
LINEAR: +/- 0.01mm									
ANGULAR:									
	NAME	SIGNATURE	DATE			TITLE: Sample			
DRAWN									
CHK'D									
APPV'D									
MFG									
Q.A					MATERIAL: Stainless Steel	DWG NO. TPDSIMS Part 11		A3	
					WEIGHT:	SCALE:2:1		SHEET 1 OF 1	

8 7 6 5 4 3 2 1

8 7 6 5 4 3 2 1

F

F

E

E

D

D

C

C

B

B

A

A

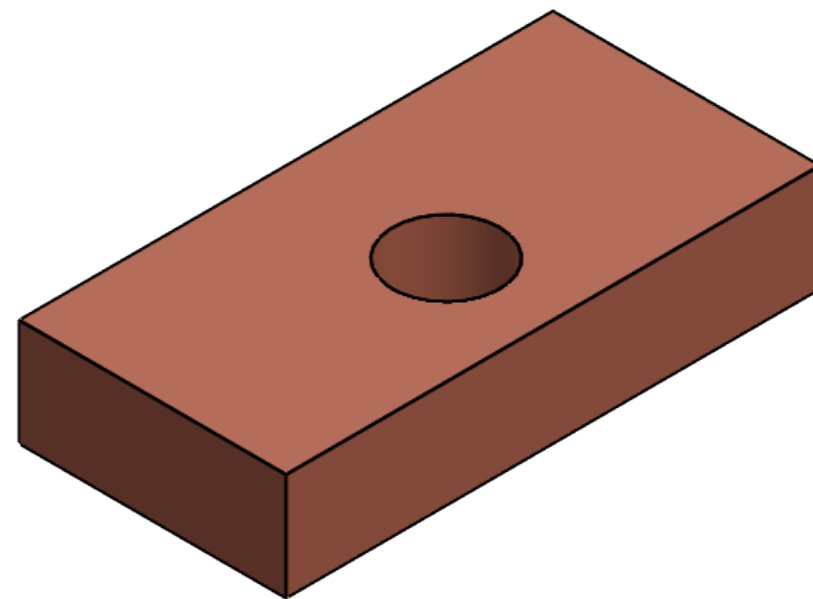
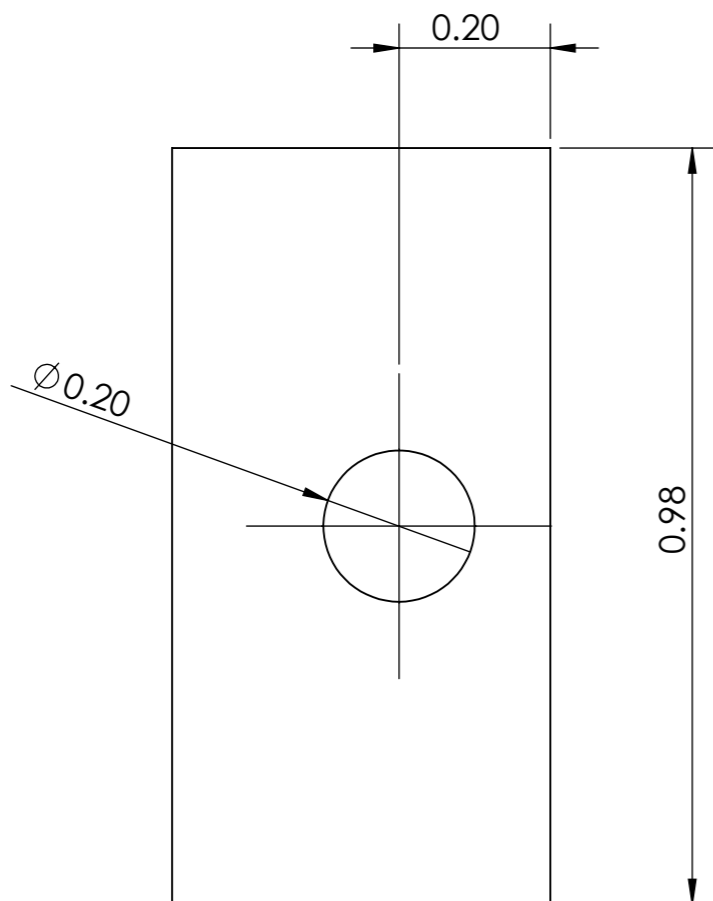
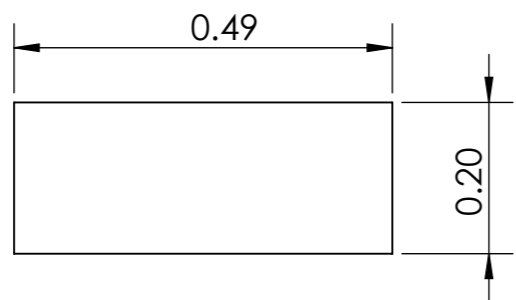

UNLESS OTHERWISE SPECIFIED: DIMENSIONS ARE IN MILLIMETERS SURFACE FINISH: TOLERANCES: +/- 0.01mm LINEAR: ANGULAR:				FINISH:		DEBURR AND BREAK SHARP EDGES		DO NOT SCALE DRAWING		REVISION	
DRAWN				NAME		SIGNATURE		DATE		TITLE: <b>Upper Copper Clamp</b>	
CHK'D											
APPV'D											
MFG											
Q.A								MATERIAL: Copper		DWG NO. TPDSIMS Part 12	
								WEIGHT:		SCALE:4:1	
										SHEET 1 OF 1	
										A3	

8 7 6 5 4 3 2 1

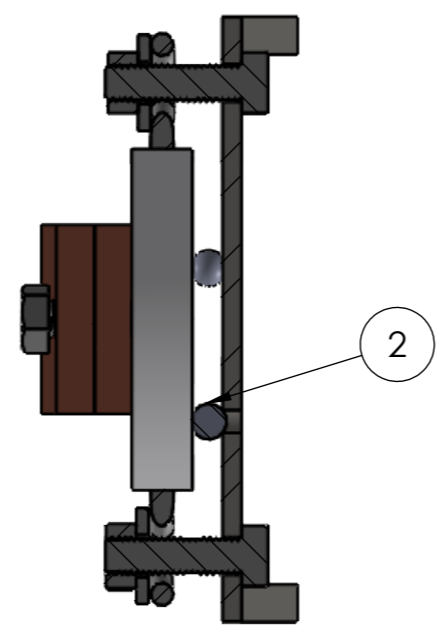
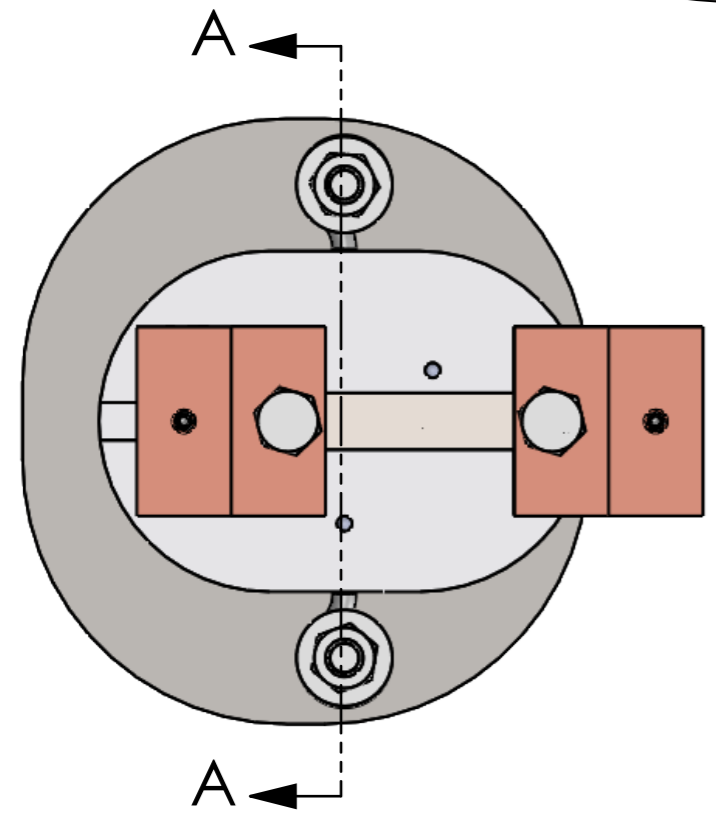
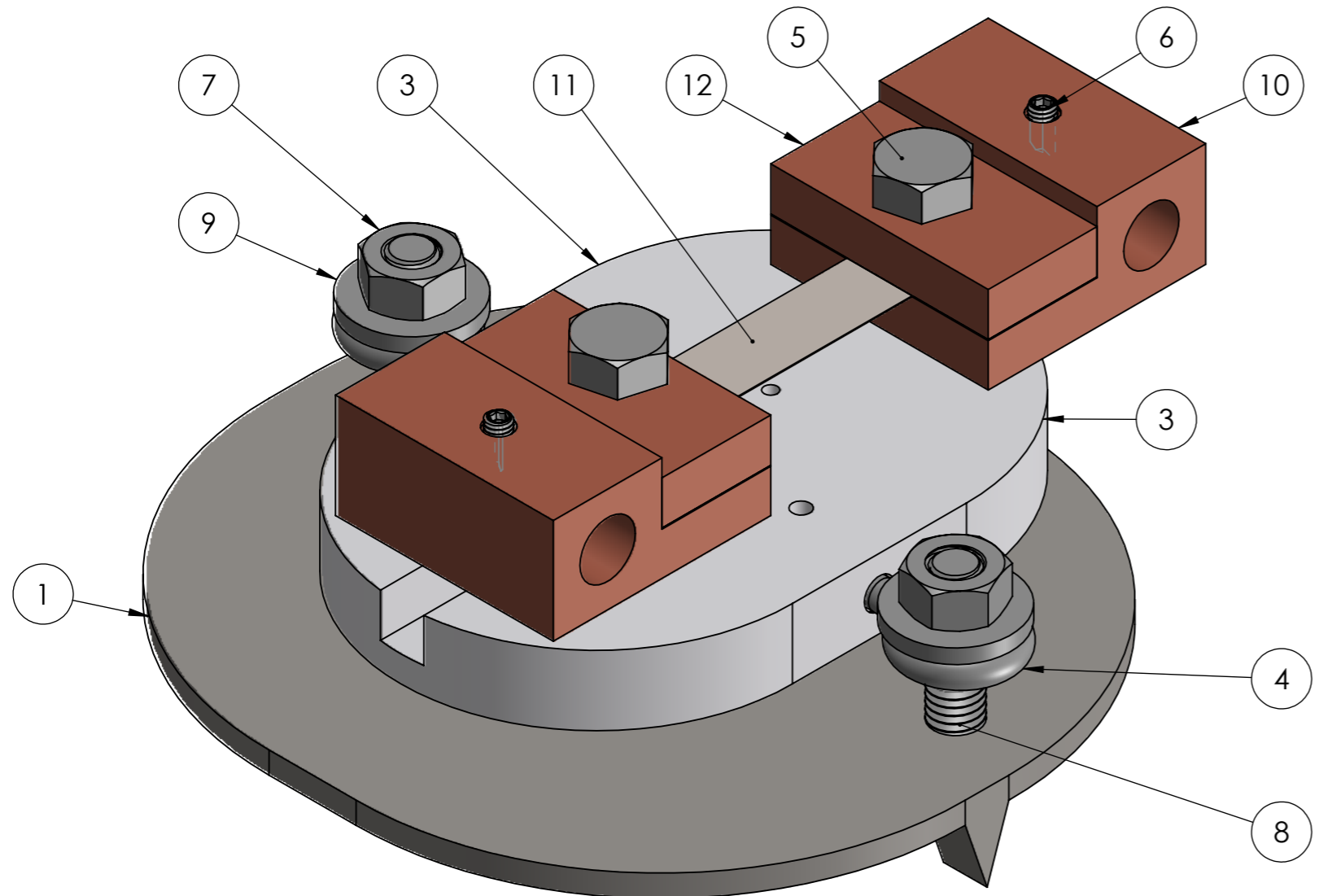

SECTION A-A

ITEM NO.	PART NUMBER	QTY.
1	Wedge	1
2	Ball Bearing	3
3	Insulator Base	1
4	Eyebolt	2
5	Hex Bolt 16mm	2
6	Set Screw	2
7	Hex Nut	2
8	Hex Bolt 18mm	2
9	Washer	2
10	Copper Clamp	2
11	Sample	1
12	Upper Copper Clamp	2

UNLESS OTHERWISE SPECIFIED: DIMENSIONS ARE IN MILLIMETERS SURFACE FINISH: TOLERANCES: LINEAR: ANGULAR:			FINISH:		DEBURR AND BREAK SHARP EDGES		DO NOT SCALE DRAWING		REVISION		
DRAWN			NAME		SIGNATURE		DATE		TITLE: <b>Sample Holder Assembly</b>		
CHK'D									DWG NO. <b>TPDSIMS Design</b>		
APPV'D									A3		
MFG									SCALE:1:1		
Q.A							MATERIAL:		SHEET 1 OF 1		
							WEIGHT:				

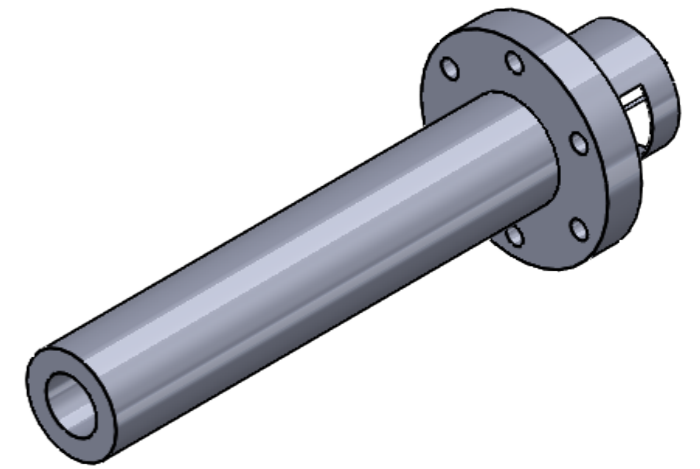
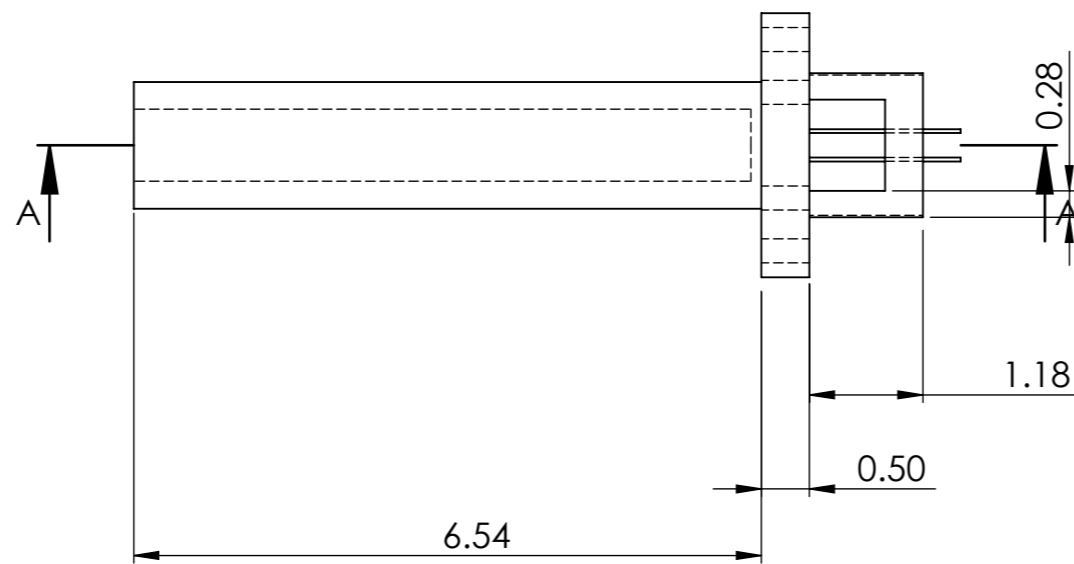
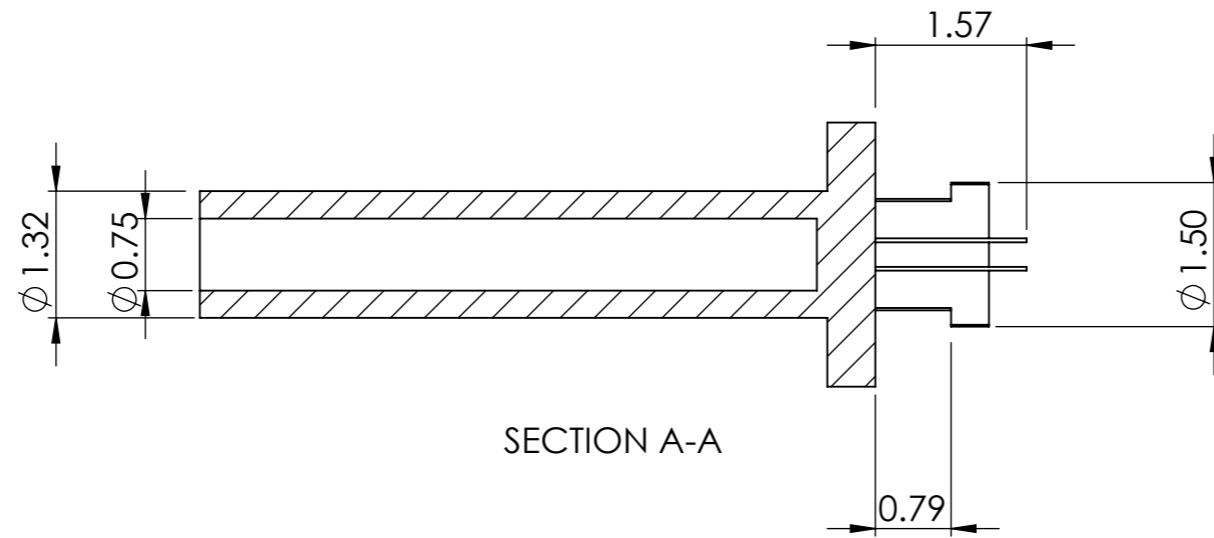
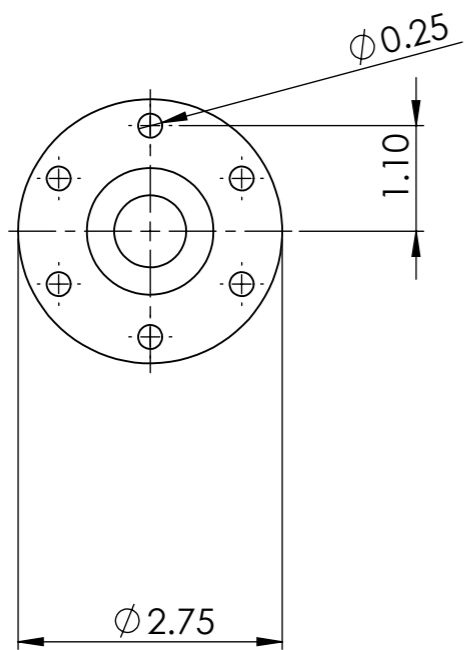

UNLESS OTHERWISE SPECIFIED: DIMENSIONS ARE IN MILLIMETERS SURFACE FINISH: TOLERANCES: LINEAR: ANGULAR:				FINISH:		DEBURR AND BREAK SHARP EDGES		DO NOT SCALE DRAWING		REVISION	
DRAWN								TITLE: <b>Flood Gun</b>			
CHK'D								DWG NO. <b>TPDSIMS Part 13</b>			
APPV'D								SCALE: 1:2			
MFG								SHEET 1 OF 1			
Q.A								A3			
MATERIAL:								WEIGHT:			

8 7 6 5 4 3 2 1

F  
E  
D  
C  
B  
A

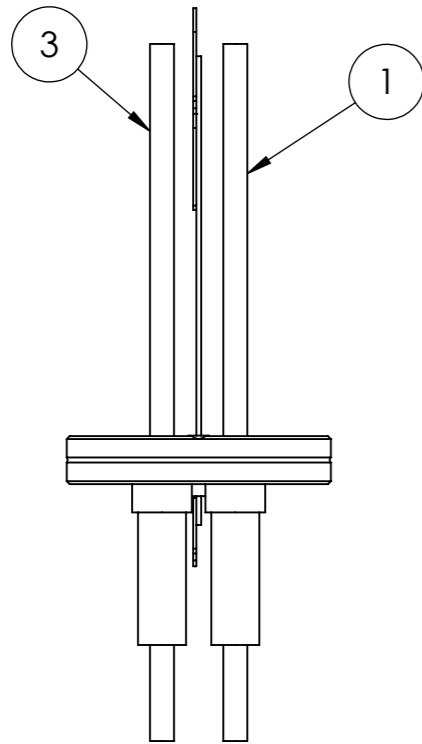
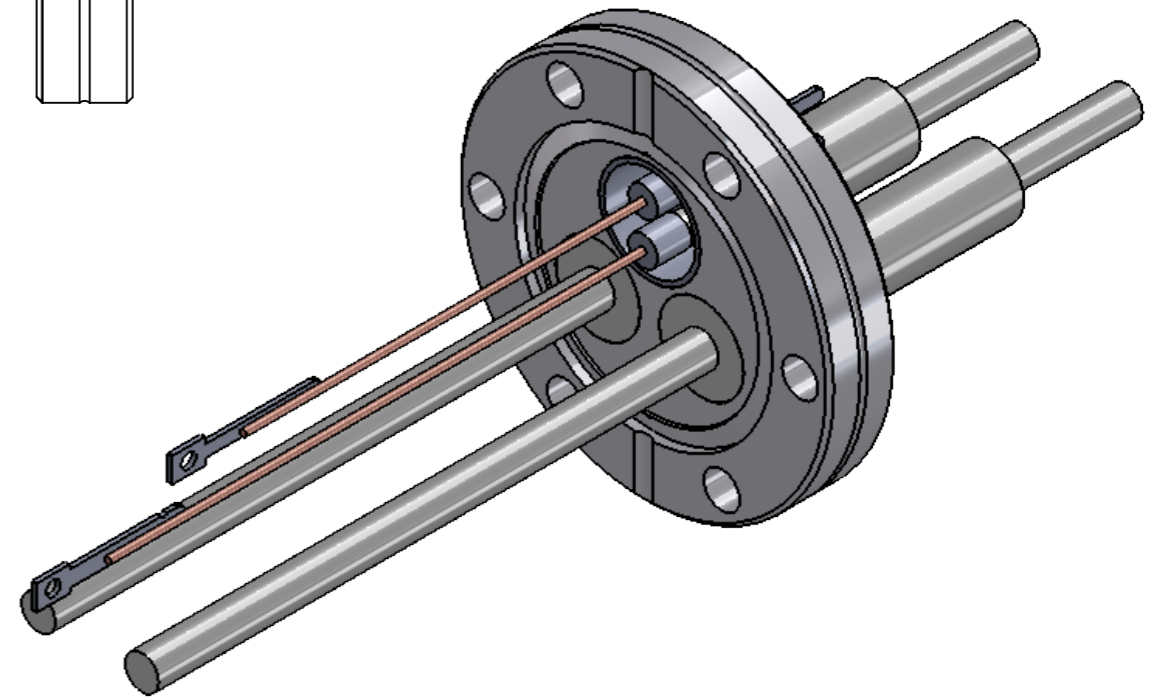
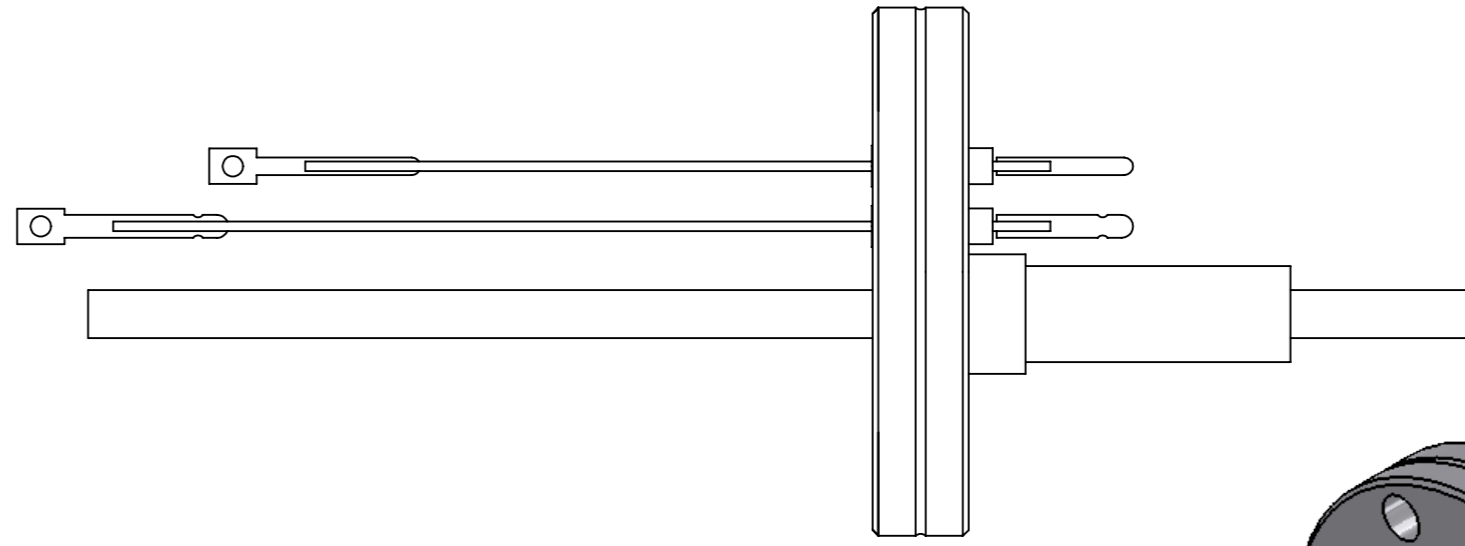
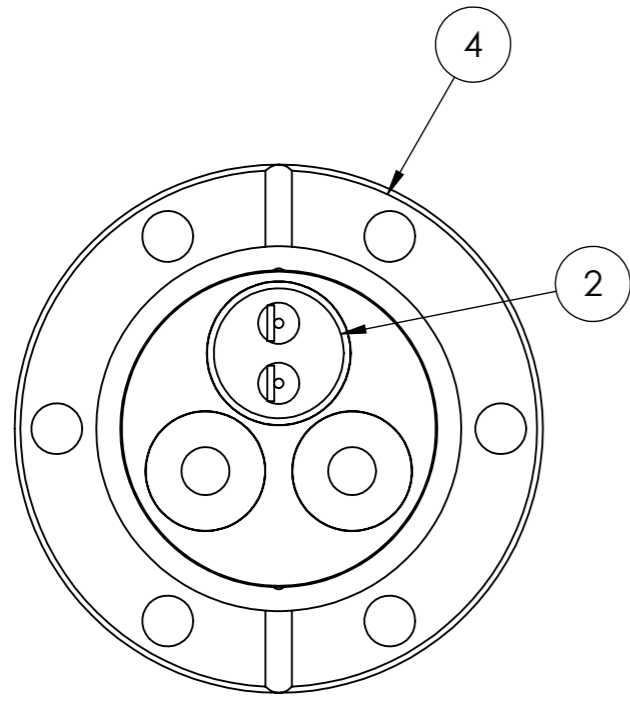

ITEM NO.	PART NUMBER	QTY.
1	F0275X000N	1
2	F0275X000N_2	1
3	F0275X000N_3	1
4	F0275X000N_4	1

UNLESS OTHERWISE SPECIFIED: DIMENSIONS ARE IN MILLIMETERS SURFACE FINISH: TOLERANCES: LINEAR: ANGULAR:			FINISH:		DEBURR AND BREAK SHARP EDGES		DO NOT SCALE DRAWING		REVISION		
DRAWN			NAME		SIGNATURE		DATE		TITLE: <b>Thermocouple and Power Feedthrough</b>		
CHK'D									DWG NO. <b>TPDSIMS Part 14</b>		
APPV'D									A3		
MFG									SCALE:1:2		
Q.A							MATERIAL:		SHEET 1 OF 1		
							WEIGHT:				

8 7 6 5 4 3 2 1

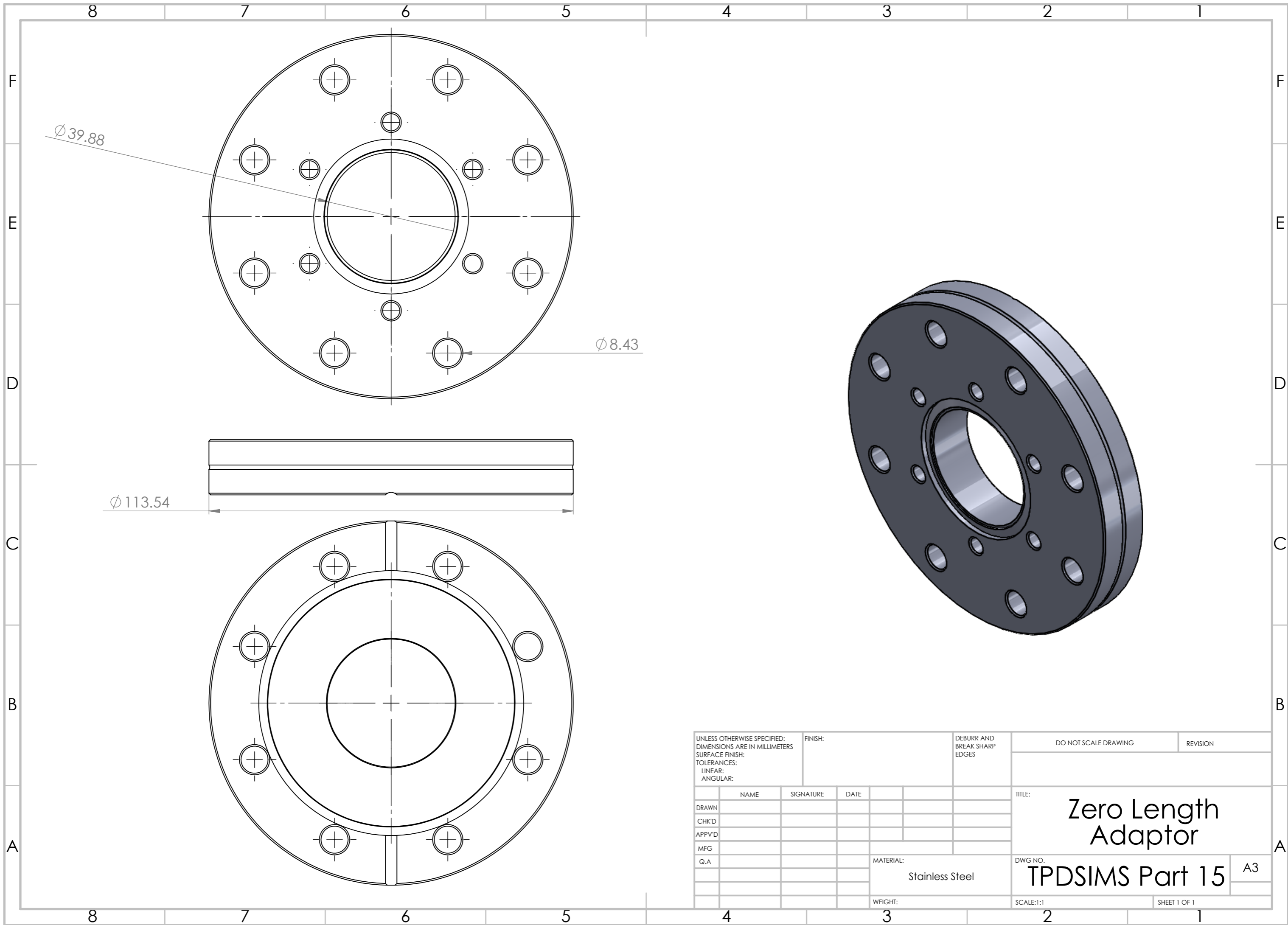

UNLESS OTHERWISE SPECIFIED: DIMENSIONS ARE IN MILLIMETERS SURFACE FINISH: TOLERANCES: LINEAR: ANGULAR:			FINISH:		DEBURR AND BREAK SHARP EDGES		DO NOT SCALE DRAWING		REVISION		
DRAWN			NAME		SIGNATURE		DATE		TITLE: <b>Zero Length Adaptor</b>		
CHK'D									DWG NO. <b>TPDSIMS Part 15</b>		
APPV'D									MATERIAL: Stainless Steel		A3
MFG									WEIGHT:		SHEET 1 OF 1
Q.A									SCALE:1:1		